

# Schlüter®-DILEX-BT

## Constructional Separation

For areas subjected to high levels of stress

# 4.20

Product data sheet



### Application and Function

**Schlüter®-DILEX-BT** is a maintenance free structural movement profile made of aluminium. The profile is designed so that the lateral anchoring legs can be either embedded in the tile adhesive layer beneath tile and natural stone coverings or integrated into the mortar bed for other covering materials, such as carpeting or vinyl. Therefore, the profile can move together with the respective covering assembly. The telescopic centre section can absorb movements of  $\pm 5$  mm. The lateral pivot joints allow for the absorption of three dimensional movement. Schlüter®-DILEX-BT offers secure edge protection for surfaces exposed to foot traffic and light vehicular traffic and is, therefore, suited for use in warehouses, production facilities, shopping centres, airports, train stations and car parks or for coverings cleaned with machines. The profile version Schlüter®-DILEX-BTO can be used to create construction joints in wall areas, while Schlüter®-DILEX-BTS allows for retrofit installation in finished coverings.

The profiles may be used in walls and ceilings made from gypsum board panels and can also be integrated directly into the plaster or render.

### Material

The profile is available in the following materials:

A = Aluminium

AE = Anodised aluminium



### Material properties and areas of application

The suitability of a proposed type of profile must be verified based on the anticipated chemical, mechanical and/or other stresses. Schlüter®-DILEX-ABT, made of aluminium, must be tested to verify its suitability if chemical stresses are anticipated. Cementitious materials, in conjunction with moisture, become alkaline. Since aluminium is sensitive to alkaline substances, exposure to the alkali (depending on the concentration and duration of exposure) may result in corrosion (aluminium hydroxide formation). Therefore, it is important to remove mortar, adhesive or grout residue from visible surfaces.

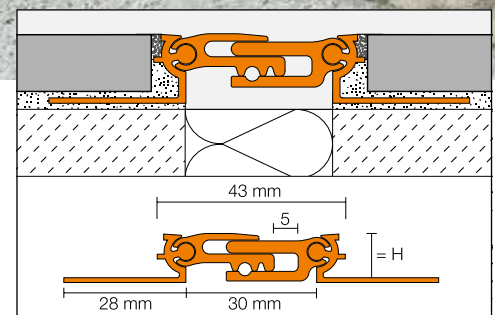

Schlüter®-DILEX-BT

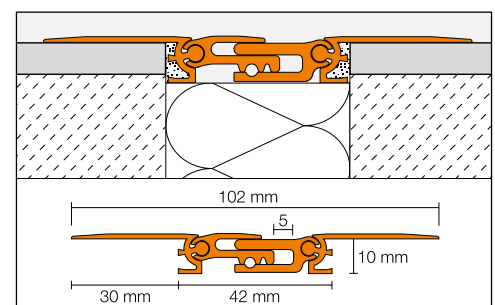

Schlüter®-DILEX-BTS



Schlüter®-DILEX-AEBT, made of anodised aluminium, features an anodised layer that retains a uniform appearance during normal use. The surface, however, is susceptible to scratching and abrasive stresses and may be damaged by grout or setting material. Therefore, it is important to remove mortar, adhesive or grout residue immediately from visible surfaces. Otherwise, the description for aluminium applies.

### Installation

1. Select Schlüter®-DILEX-BT in accordance with tile thickness.
2. Using a notched trowel, apply tile adhesive to the area where the tile covering will end.
3. Press the perforated anchoring leg of Schlüter®-DILEX-BT into the adhesive bed and align.
4. Completely cover the perforated anchoring leg with tile adhesive.
5. Align the adjoining tiles and adjust them in such a way that the upper lip of the profile is flush with the tile. Note: The profile should not be higher than the tile, but flush or up to approximately 1 mm lower. All tiles in the profile area must be completely set. Always lay the uncut section of a tile against the profile.
6. The tile is set to the lateral joint spacer, which ensures a uniform joint of 1.5 mm.
7. Fill the joint cavity between the tile and the profile completely with grout and immediately remove the protective foil.
8. For installations into a mortar screed, strips of mortar, divided by an insulating strip, are placed on either side of the structural joint.
- 8a. Apply a contact layer consisting of dry set mortar or cement slurry over the mortar strips.
- 8b. Set Schlüter®-DILEX-BT into the contact layer, align and tap in.
- 8c. Apply enough screed material so that the surface of the covering to be used is flush with the upper lip of the profile. Select the profile height to ensure the anchoring leg is covered by approximately 15 mm of screed.
9. The installation of Schlüter®-DILEX-BT on walls and ceilings is essentially equivalent to floor applications.
10. Schlüter®-DILEX-BTS can be inserted into existing joint spaces. The joints must be at least 44 mm wide and 10 mm deep. The lateral anchoring legs are adhered to the existing covering with a suitable adhesive (e.g. epoxy resin), or the anchoring legs are drilled and screwed to the covering. Depending on the attachment or anchoring, Schlüter®-DILEX-BTS has limited mechanical load capacities. Flush installation is recommended for areas with heavy traffic loads.



### Maintenance

Schlüter®-DILEX-BT requires no special maintenance or care. The oxidation layer on aluminium can be removed with conventional polishing agents, but will continue to form. Damaged anodised surfaces can be restored with paint.



## Product Overview

### Schlüter®-DILEX-BT

A = aluminium, AE = anodised aluminium

Length supplied: 2.50 m

Material	A	AE
H = 8 mm	•	•
H = 10 mm	•	•
H = 12.5 mm	•	•
H = 15 mm	•	•
H = 17.5 mm	•	•
H = 20 mm	•	•

### Schlüter®-DILEX-BTO

A = aluminium, AE = anodised aluminium

Length supplied: 2.50 m

Material	A	AE
H = 8 mm	•	•
H = 10 mm	•	•
H = 12.5 mm	•	•
H = 15 mm	•	•
H = 17.5 mm	•	•
H = 20 mm	•	•

### Schlüter®-DILEX-BTS

A = aluminium, AE = anodised aluminium

Length supplied: 2.50 m

Material	A	AE
H = 10 mm	•	•

Note: The different profile heights can also be combined as needed.

Floor to wall transition: (Schlüter®-DILEX-BTO):

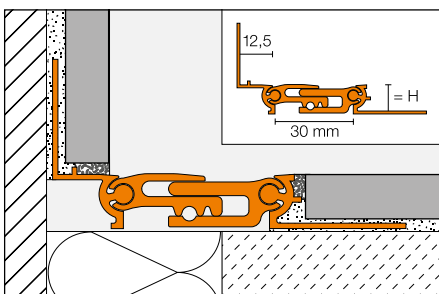

**Text template for tenders:**

## Supply

\_\_\_\_\_ linear metres of Schlüter®-DILEX-BT, as a structural expansion joint

- A = Aluminum
- AE = Anodised aluminium

including trapezoid perforated anchoring legs, lateral pivot joint and a telescopic centre section, to be professionally installed while observing the manufacturer's instructions in the following:

- Floor coverings made of tile or natural stone
- Screed areas
- Wall areas of tile or natural stone
- Plaster areas
- Gypsum board
- Ceiling areas

## Profile height

(depending on tile thickness): \_\_\_\_\_ mm

Art.-No.: \_\_\_\_\_

Material: \_\_\_\_\_/m

Labour: \_\_\_\_\_/m

Total: \_\_\_\_\_/m

**Text template for tenders:**

## Supply

\_\_\_\_\_ linear metres of Schlüter®-DILEX-BTS, as a structural expansion joint

- A = Aluminum
- AE = Anodised aluminium

for retrofitting in completed coverings, with lateral pivot joint and telescopic centre section, to be professionally installed in the following areas, while observing the manufacturer's instructions:

- Floor areas consisting of:

\_\_\_\_\_

- Screed areas
- Wall areas consisting of:

\_\_\_\_\_

- Plaster areas

- Drywall

- Ceiling areas

Art.-No.: \_\_\_\_\_

Material: \_\_\_\_\_/m

Labour: \_\_\_\_\_/m

Total: \_\_\_\_\_/m

**Text template for tenders:**

## Supply

\_\_\_\_\_ linear metres of Schlüter®-DILEX-BT/O, as a structural expansion joint

- A = Aluminum
- AE = Anodised aluminium

including trapezoid perforated anchoring legs, lateral pivot joint and a telescopic centre section, to be professionally installed while observing the manufacturer's instructions in the following:

- Floor coverings made of tile or natural stone
- Screed areas
- Wall areas of tile or natural stone
- Plaster areas
- Gypsum board
- Ceiling areas

## Profile height

(depending on tile thickness): \_\_\_\_\_

Art.-No.: \_\_\_\_\_

Material: \_\_\_\_\_/m

Labour: \_\_\_\_\_/m

Total: \_\_\_\_\_/m

**Application areas depending on local traffic load****Foot traffic**

Total weight -

**Shopping carts**

Total weight max. 0.4 t

**Cars**

Total weight max. 3.5 t

**Trucks**

Total weight max. 40 t

**Forklifts**

*Pneumatic tyres*

Total weight max. 5 t

*Solid rubber tyres*

Total weight max. 2.5 t

**Pallet trucks**

*Hard rubber tyres*

Total weight max. 1.0 t

(Pallet trucks must have tandem axles)

● Suitable

● Unsuitable